

Installation Instructions for the Ford Fast Tapping Sleeve

Refer to the Ford website (<http://www.fordmeterbox.com>) for additional and most recent installation instructions and product information.

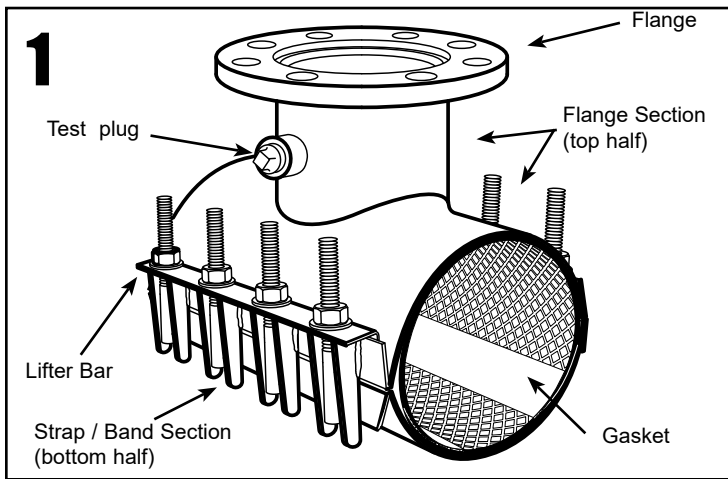

1. Your FAST Tapping Sleeve is warranted to be free of defects at time of shipment. Please visually inspect before installing to ensure that no damage has occurred during shipment or storage.

Clean any dirt, corrosion, or foreign material from pipe, measure the outside diameter, and check it against the FAST Tapping Sleeve to ensure you have the correct size. Lubricate the pipe under and beyond the gasket contact area with a thin coating of pipe joint lubricant.

Note: Extra attention must be given to the lubrication of AC pipe due to its rough and absorbent nature. If it becomes absorbed, apply more lubricant to AC pipe.



2. Disassemble the tapping sleeve and remove the nuts, washers, and lifter bar from one side of the bolt section. Back the nuts to extreme end of bolts on the other side. Note: Units for 4" nominal pipe require removal of nuts on both sides.

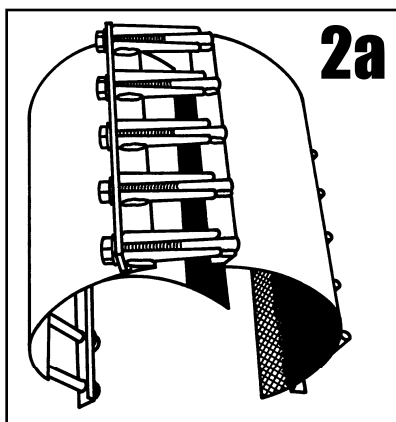
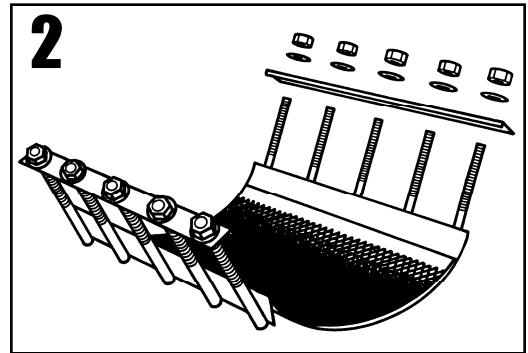

2a. Alternate instructions for 3-section design.

Large diameter sleeves are designed so that the two strap sections may be loosely fastened together for easier installation. Assemble the two sections together leaving the nuts at the extreme end of the bolts. **DO NOT COMPLETELY TIGHTEN THE NUTS UNTIL STEP 7.**

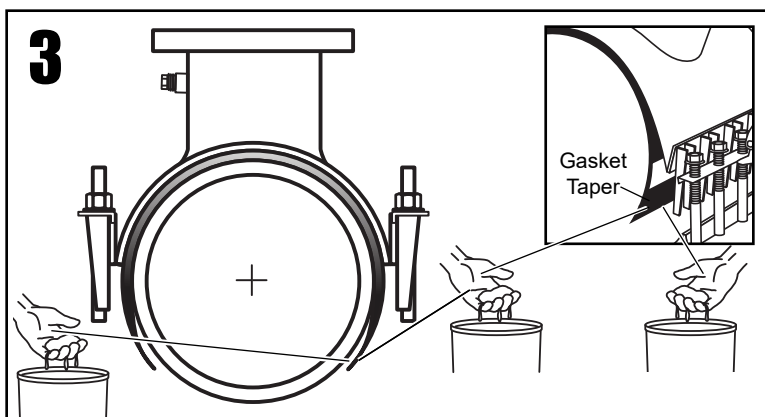

3. Set the flanged section on the top of the pipe. (This will help support the weight of the unit.) Lightly lubricate the outside, smooth surface of the gasket tapers. On some sizes, the tapers will overlap each other to completely encircle the pipe.

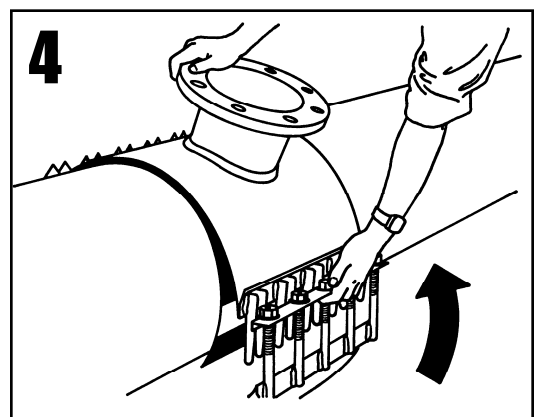

4. Attach the lifter bar end of the bolt section to one side of the flange section. Do not tighten at this time.

Make sure tapered ends of gasket are not folded or rolled against pipe.

5. Pull the other end of strap section (the end with nuts and lifter bar removed) around the pipe, making sure no foreign material is trapped between the pipe and gasket. Position the bolts in the lugs on the saddle section and install the lifter bar, washers, and nuts. Do not tighten nuts. The lifter bar should be hooked over the lug/side bar assembly.

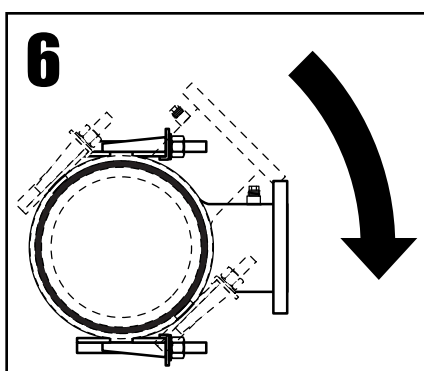
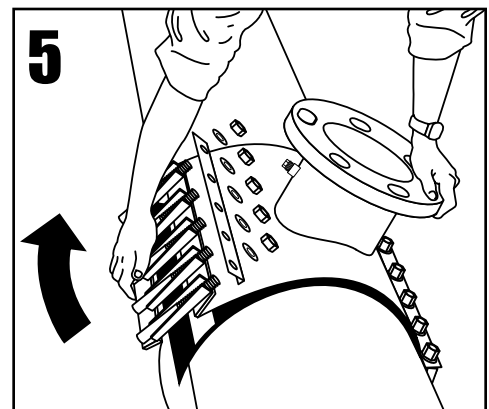

6. With **PIPE AND GASKETS LUBRICATED**, carefully rotate the flange to the desired angle and check with a level to ensure flange is perfectly vertical and in line with the intended lateral. Make sure all gaskets are flat against the pipe. Hand tighten several nuts at each location to hold the unit in place.

7. Beginning with the center bolts joining each section, partially tighten the bolts to reduce the gaps between sections. Work outwardly to each end, partially tightening bolts to maintain an even gap between all sections and from end to end.

To achieve proper torque and gaps, partially tighten each bolt several times using the above sequence. (Work from the middle bolt to the ends, and repeat this process on all other sections before increasing torque.) Do not completely close up the gap on one section and attempt to apply proper torque to the other sections.

Continue to tighten the bolts to the recommended torque stated in the table below.

RECOMMENDED TORQUE VALUES

STUD SIZE (Nom.)	5/8"		3/4"
FLANGE SIZE (Nom.)	3" - 10"	12"	All Sizes
TORQUE (ft-lb)	75	90	110

At final torque, gaps between sections must be the same (within 1/16" tolerance) at each location and equal from end to end.

Final torque must also be checked several times, including after the tap is made, because gasket compression may reduce torque.

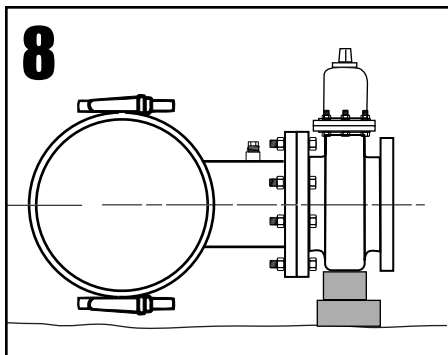
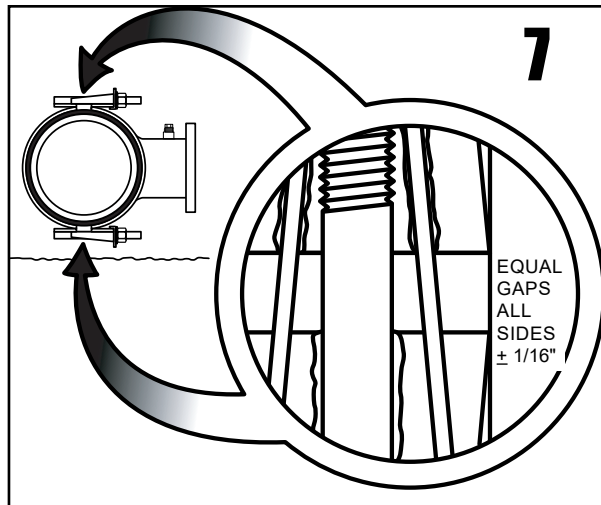

8. Use a tapping valve flange gasket, drop-in/ring style that fits inside the bolt circle, or a Ford CSFG cap gasket.

Attach tapping valve to sleeve and block to support valve's suspended weight. Tapping sleeve and valve flanges must mate properly to ensure a straight center line axis. This is necessary to prevent cutter from hitting sides of sleeve outlet.

9. Close valve. Test valve and sleeve assembly using the tapping sleeve test plug. AWWA C223 recommends "...the installer hydrostatically [water] test the seal between the gasket and pipe. For personal safety reasons, do not use a compressible fluid medium (such as air) to check for water tightness." Check for leaks between pipe, sleeve, and valve. If a leak is observed, relieve the pressure and re-tighten the bolts to the recommended torque. Maximum recommended torque is shown in the following table.

MAXIMUM TORQUE VALUES

STUD SIZE (Nom.)	5/8"		3/4"
FLANGE SIZE (Nom.)	3" - 10"	12"	All Sizes
TORQUE (ft-lb)	100	115	135

If leak continues, remove tapping sleeve, re-clean the pipe, and re-install the sleeve to reset the gasket against the pipe surface.

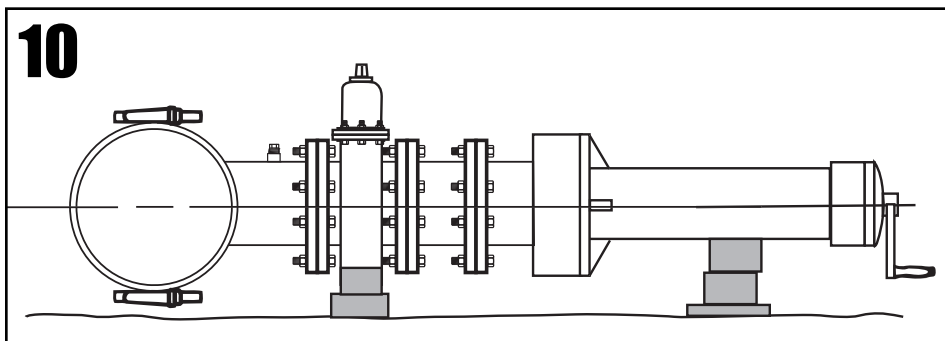
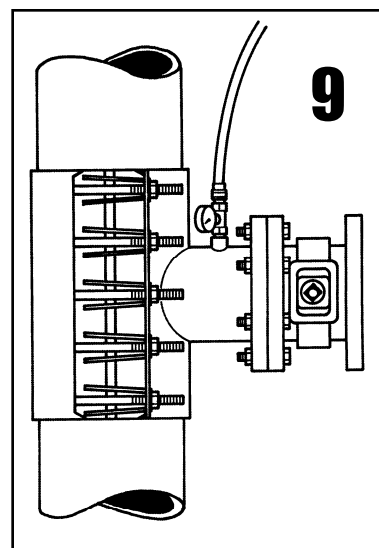

10. Attach drilling machine to tapping valve, block, and check for proper mating and alignment between valve and machine.

11. Make the following checks before proceeding with tap.
- Gaps between each section are equal from side to side and from end to end.
 - All clamping bolts are tightened to the proper torque.
 - All blocking is in place and secure.
 - Correct size cutter has been selected for job.
Fast Tapping Sleeves allow a full size cutter.

RECOMMENDED TORQUE VALUES

STUD SIZE (Nom.)	5/8"		3/4"
FLANGE SIZE (Nom.)	3" - 10"	12"	All Sizes
TORQUE (ft-lb)	75	90	110

12. Re-check tapping sleeve bolt torque after tap and before backfilling. Stress induced during tapping may relax bolt torque. A visual indicator of proper torque is a slight deformation of the lifter bar at each stud location. **The use of a torque wrench is recommended and required to ensure proper torque.**

13. To prevent undue stress on the Tapping Sleeve and Valve assembly, make sure the new watermain will rest on a well compacted bed with its center line axis matching the center line axis of the Tapping Valve.

